

| Rev | Comment | Date | Ini |
|-----|---------|------|-----|
| | | | |
| | | | |
| | | | |

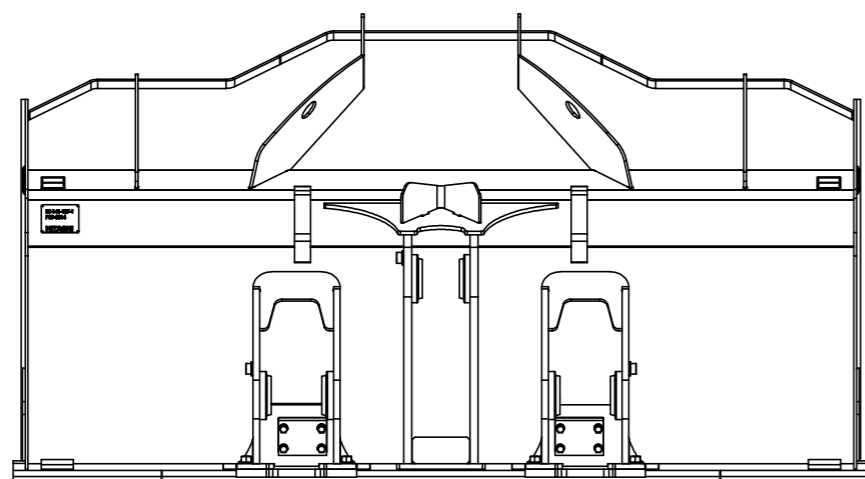
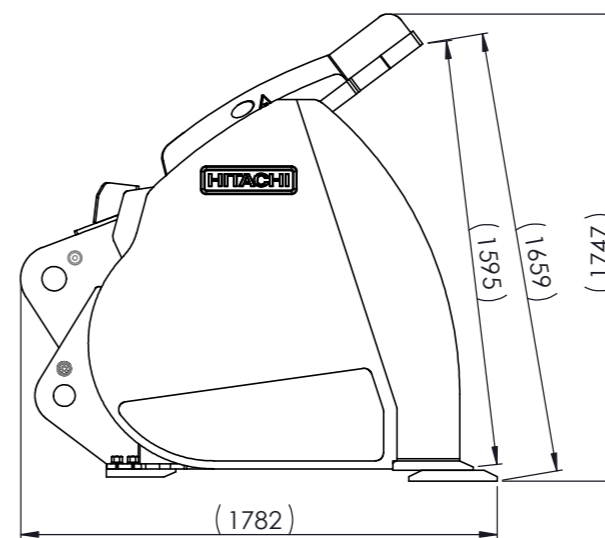
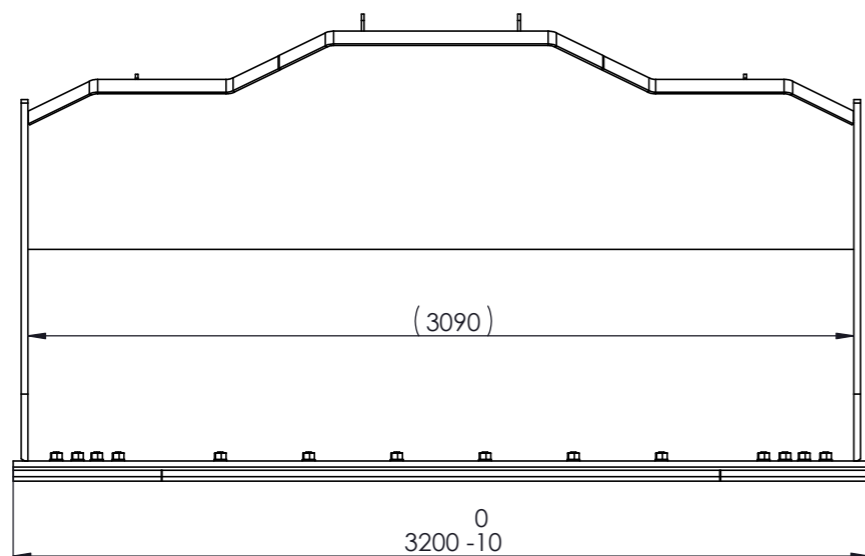

| HITACHI | | (GP Bucket) Description | Matreial type | Thickness |
|----------------------|-------------------|---------------------------|---------------|-----------|
| Machine type: | ZW310-6 | Bottom plate | HX 450 | 10mm |
| Hitachi part No: | E0A001453 | Back plate | HX 450 | 10mm |
| SAE heapes capacity: | 4,6m ³ | Side cutting edge | HX 450 | 25mm |
| Width: | 3200mm | Side plate | HX 450 | 10mm |
| Max. Payload: | 7150kg | Side wear plate | HX 450 | 10mm |
| Dumping height | XXX | Cutting edge | HB 500 | 300x35mm |
| Dumping clearaince | XXX | Bolt-on edge | HB 500 | 330x40mm |

Unless otherwise stated the following applies

Machined Surface: 3.2/√ General Machining tolerances: DS/EN 22768-m
Welding tolerances: DS/EN 13920 B, Welding quality: DS/EN ISO 5817 - D

| | | | | |
|----------------|-----------------|-------------------|-----------|-----------|
| HITACHI | Note1: | 4,6m ³ | Part No.: | E0A001453 |
| | Note2: | 3200mm | Material: | |
| | Note3: | 7150 kg | Creator: | AM |
| | Description: | ZW310-6 GP RF DM | | |
| | Surface finish: | Surface area: | | |

THIS DRAWING REMAINS THE PROPERTY OF SJØRRING MASKINFABRIK A/S. ANY REPRODUCTION IN PART OR AS A WHOLE WITHOUT THE WRITTEN PERMISSION OF SJØRRING MASKINFABRIK A/S IS PROHIBITED.

| Date | Filename | Scale | Weight |
|------------|----------|-------|---------|
| 2020-05-29 | P40-0389 | 1:20 | 2612 kg |

| Rev | Comment | Date | Ini |
|-----|---------|------|-----|
| | | | |
| | | | |
| | | | |

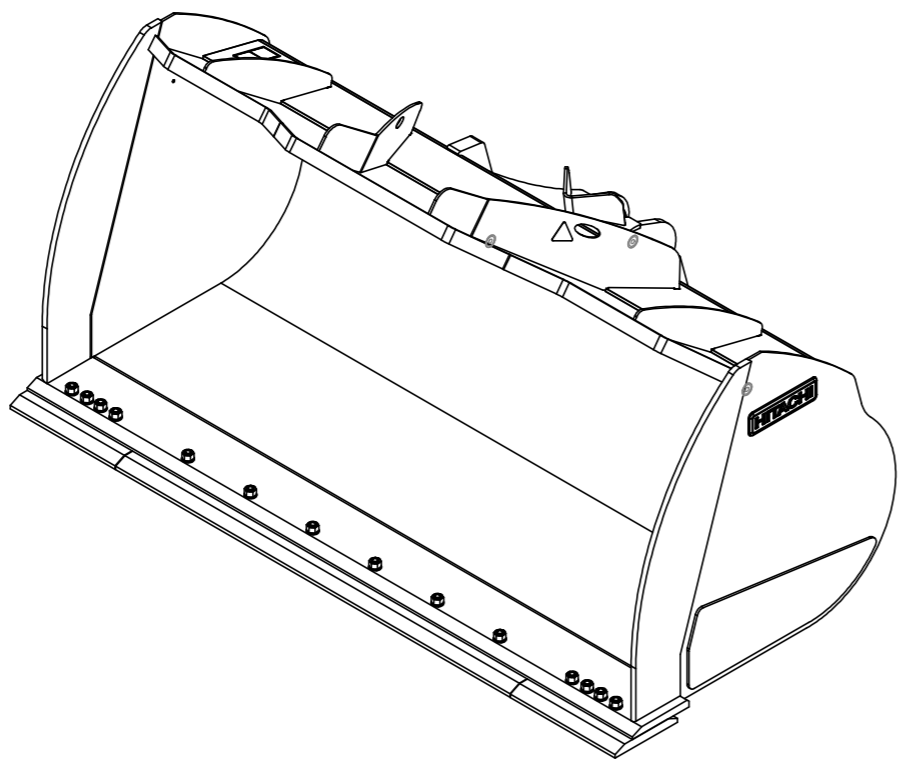
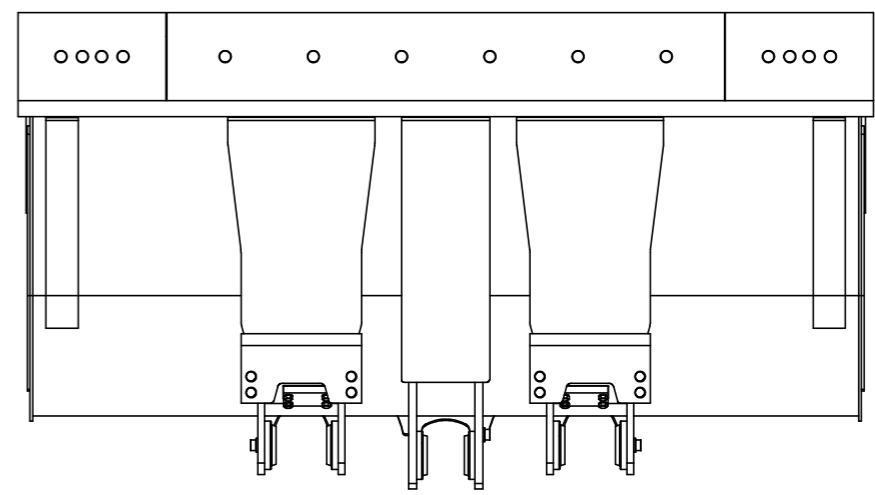
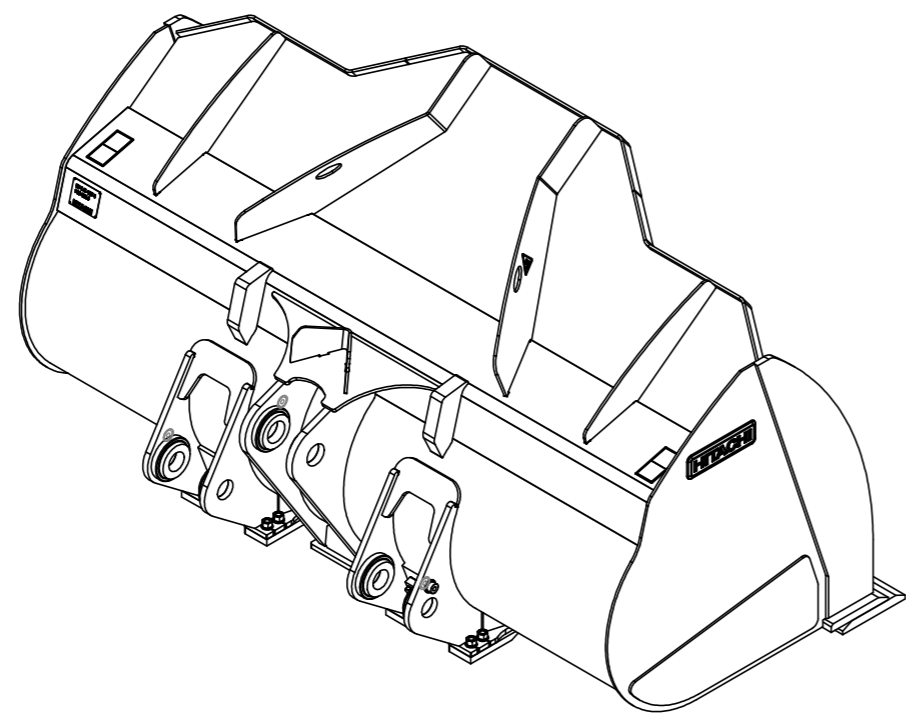

| Unless otherwise stated the following applies | | | |
|---|---|-------------------------------|--------------------------|
| Machined Surface: 3.2/√ | General Machining tolerances: DS/EN 22768-m Welding tolerances: DS/EN 13920 B, Welding quality: DS/EN ISO 5817 - D | | |
| HITACHI | Note1: 4,6m ³ | Part No.: E0A001453 | |
| | Note2: 3200mm | Material: | |
| | Note3: 7150 kg | Creator: AM | |
| | Description: ZW310-6 GP RF DM | | |
| | Surface finish: | | Surface area: |
| THIS DRAWING REMAINS THE PROPERTY OF SJØRRING MASKINFABRIK A/S. ANY REPRODUCTION IN PART OR AS A WHOLE WITHOUT THE WRITTEN PERMISSION OF SJØRRING MASKINFABRIK A/S IS PROHIBITED. | | | |
| Date 2020-05-29 | Filename P40-0389 | Scale 1:20 | Weight 2612 kg |

| Rev | Comment | Date | Ini |
|-----|---------|------|-----|
| | | | |
| | | | |
| | | | |

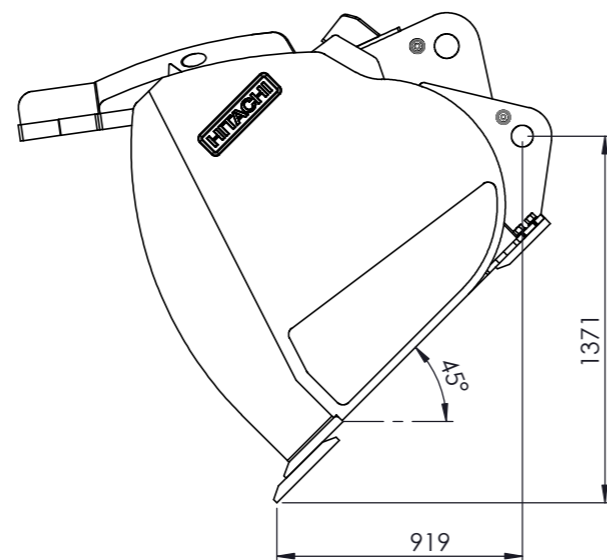
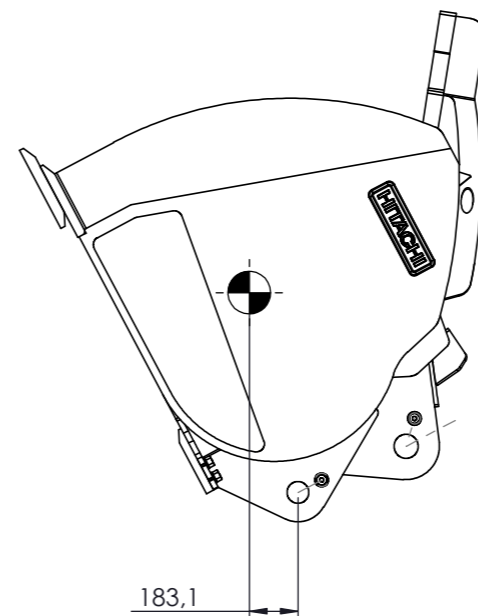
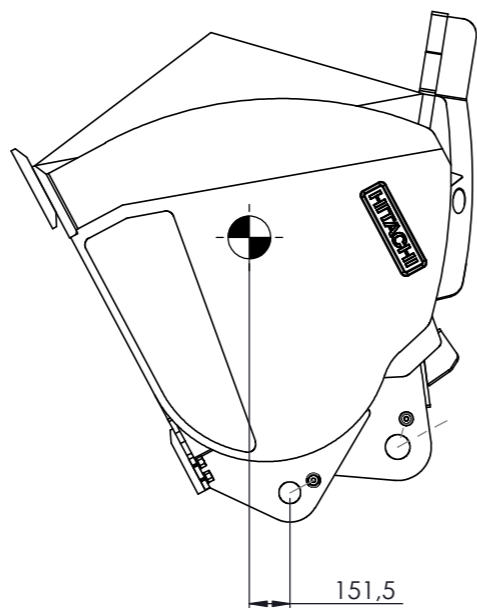

| Unless otherwise stated the following applies | | | |
|---|---|-------------------------------|--------------------------|
| Machined Surface: 3.2/√ | General Machining tolerances: DS/EN 22768-m Welding tolerances: DS/EN 13920 B, Welding quality: DS/EN ISO 5817 - D | | |
| HITACHI | Note1: 4,6m ³ | Part No.: E0A001453 | |
| | Note2: 3200mm | Material: | |
| | Note3: 7150 kg | Creator: AM | |
| | Description: ZW310-6 GP RF DM | | |
| Surface finish: | | Surface area: | |
| Date 2020-05-29 | Filename P40-0389 | Scale 1:20 | Weight 2612 kg |
| THIS DRAWING REMAINS THE PROPERTY OF SJØRRING MASKINFABRIK A/S. ANY REPRODUCTION IN PART OR AS A WHOLE WITHOUT THE WRITTEN PERMISSION OF SJØRRING MASKINFABRIK A/S IS PROHIBITED. | | | |